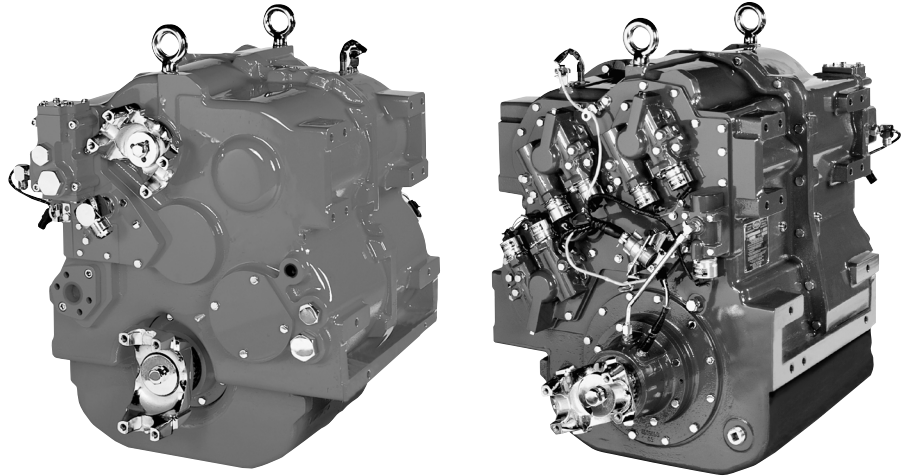

TD61-1180**UP TO 705 HP (526 kW)**

The 1180 transmission system consists of an engine mounted 17.5 or 18.5 inch type 8 torque converter, a 6 speed power-shift transmission and an advanced electronic control system.

**FEATURES & BENEFITS**

- INCREASED POWER AND TORQUE CAPACITY TO MATE WITH MODERN 4-CYCLE HIGH TORQUE ENGINES.
- FULL TIME ALL WHEEL DRIVE WITH DIFFERENTIAL LOCK. 30-70 AND 50-50 BIASING DIFFERENTIALS AVAILABLE FOR 4X4, 6X6 AND 8X8 VEHICLES. OPTIONAL PART TIME AWD SYSTEM AVAILABLE.
- HIGH CAPACITY PTO CLUTCH WITH ABILITY TO SHIFT AT ANY ENGINE SPEED.
- STATE OF THE ART TDEC-400 ELECTRONIC CONTROL SYSTEM.
- INCREASED FIRE FIGHTING EFFICIENCY: THE TWIN DISC TRANSMISSION SYSTEM PERMITS FASTER SHIFTS, RAPID ACCELERATION AND PRECISE CONTROL OF VEHICLE SPEED TO MEET GROUND REQUIREMENTS AND VARYING TRACTIVE CONDITIONS. THE VEHICLE GETS TO LOCATION FASTER AND STARTS PUMPING SOONER TO FIGHT LIFE-THREATENING FIRES QUICKLY.
- EASE OF USE: ADVANCED ELECTRONIC CONTROL SYSTEM TAILORED FOR ARFF VEHICLES INTEGRATES THE CONTROL OF DRIVE MODE, PTO ENGAGEMENT, PUMP AND ROLL MODE AND FREES THE VEHICLE OPERATOR TO CONCENTRATE ON THE PRIMARY MISSION. SIMPLE OPERATION REDUCES TRAINING REQUIREMENTS.
- REDUCED DOWNTIME: DURABLE HEAVY-DUTY COMPONENTS, COMBINED WITH ELECTRONIC CONTROLS WHICH PREVENT OVERSPEED, SHIFT SHOCKS AND REDUCE THE EFFECTS OF OPERATOR'S ERROR, RESULT IN INCREASED MACHINE AVAILABILITY AND LESS WEAR AND TEAR ON OTHER MACHINE COMPONENTS.
- EXTENDED SERVICE LIFE: THE 1180 TRANSMISSION SYSTEM UTILIZES THE SAME COMPONENTS USED IN HEAVY-DUTY OFF-HIGHWAY UNITS. THIS ASSURES LONG LIFE IN ARFF VEHICLE OPERATION.
- INTEGRATED SYSTEM COMPONENTS: TORQUE CONVERTER WITH INTEGRAL POWER DIVIDING, DROP BOX-TYPE TRANSMISSION AND ADVANCED ELECTRONIC CONTROLS ARE ALL DESIGNED TO WORK TOGETHER AS A SYSTEM RATHER THAN A COLLECTION OF PARTS.

RATIOS

	1st	2nd	3rd	4th	5th	6th	Reverse	Overall
TD61-1180	6.70	4.39	2.90	1.89	1.24	0.82	7.44	8.18

Specifications subject to change without prior notice in the interest of continual product improvement. Contact your local Twin Disc representative for engineering specifications.



TD61-1180 TRANSMISSION SYSTEM FOR ARFF VEHICLES

Dimensions are in mm (inches)

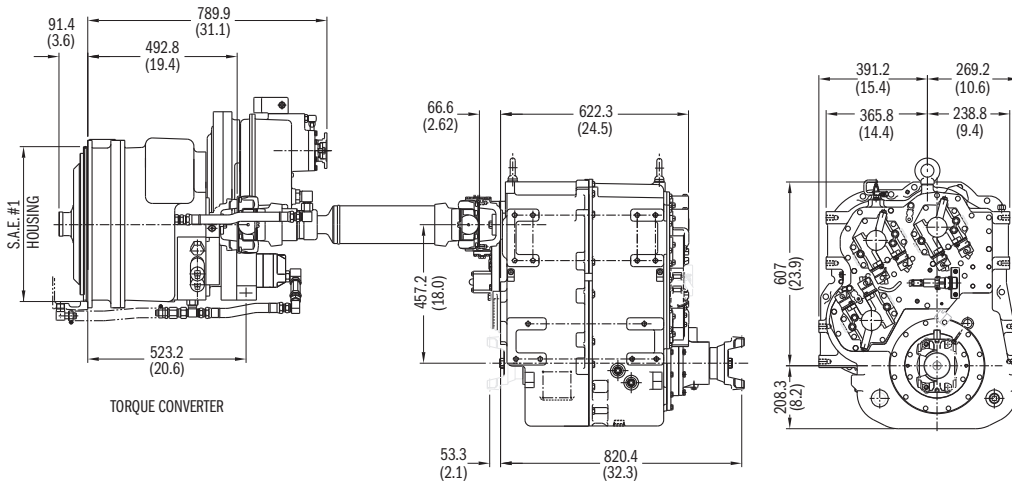

SPECIFICATIONS

Maximum gross input power (ARFF only)	705 hp (526 kW) @ 2100 RPM
Maximum gross input torque (ARFF only)	1907 lb-ft (2585 Nm)
Maximum input speed	2300 RPM
Weight	1700 lbs. (770 kg)
Maximum oil temperature at converter outlet	250° F
Sump capacity	7 USG (26.5 liters)
Cooling required	~25% of GHP
Cooling pump capacity	~46.5 GPM @ 2100 RPM
Remote mounted	
30-70, 50-50, 70-30 with differential lock	
TD61-1180 output rotation opposite engine for forward	
Consult Twin Disc regarding availability and specifications for optional outputs, PTOs and accessories	

Important Notice: Torsional Vibration

Disregarding system torsional compatibility could cause damage to components in the drive train resulting in loss of mobility. At minimum, system incompatibility could result in gear clatter at low speeds.

The responsibility for ensuring that the torsional compatibility of the system is satisfactory rests with the assembler of the drive and driven equipment.

Torsional vibration analysis can be made by the engine builder, independent consultants and others. Twin Disc is prepared to assist in finding solutions to potential torsional problems that relate to the transmission.

Twin Disc, Incorporated reminds users of these products that their safe operation depends on use in compliance with engineering information provided in our catalog. Users are also reminded that safe operation depends on proper installation, operation and routine maintenance and inspection under prevailing conditions. It is the responsibility of users (and not Twin Disc, Incorporated) to provide and install guards or safety devices which may be required by recognized safety standards or by the Occupational Safety and Health Act of 1970 and its subsequent provisions.

United States of America • Australia • Belgium • France • Italy • Singapore • Switzerland

For nearly a century, we've been putting horsepower to work by designing, engineering and manufacturing rugged-duty industrial products. Our products and our reputation are bolted to the most renowned engine manufacturers and equipment OEMs in the world. Our mission is to make your machines and vehicles more productive, more durable, more operator-friendly, more cost-effective. From design and installation consultation through after-sale support, Twin Disc and its distributors are committed to your business. No one knows more about managing horsepower in more ways than Twin Disc.

TRANSMISSIONS • CLUTCHES • PTOs
PUMP DRIVES • TORQUE CONVERTERS
GEARBOXES • HYDRAULIC PTO PRODUCTS



Twin Disc, Incorporated
Racine, Wisconsin 53403 USA
Phone +1-262-638-4000
Fax +1-262-638-4482
www.twindisc.com

TD-Bulletin-TD61-1180ARFF
© 2014, Twin Disc, Incorporated
Printed in the USA - 01/2014