

TA90-8703

UP TO 3300 HP (2460 KW)

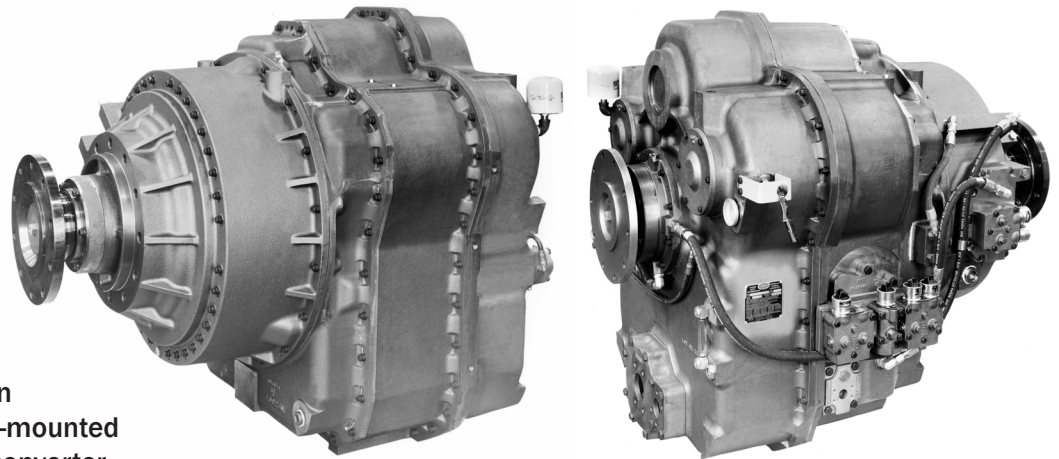

The 8703 Series transmission system consists of an engine-mounted 21 or 23 inch type 8 torque converter, a 9 speed coaxial power-shift transmission and the advanced TDEC-500 electronic control system.

FEATURES & BENEFITS:

- **Increased Performance:** Efficient gear train combined with electronic controls tailored to the needs of the specific application to optimize machine performance.
- **Ease of Operation:** Available automatic shifting or manual power shift combined with shift inhibits and interlocks simplify the operator's job and allows for concentration on the job rather than the powertrain.
- **Reduced Downtime:** Durable heavy-duty components, combined with electronic controls which prevent overspeed, shift shocks and reduce the effects of operator error, result in increased machine availability and less wear and tear on other machine components.
- **Safety:** The control system looks after the transmission so the operator can focus on the operation of the machine. Speeds and interlocks can be programmed to meet the needs of the specific machine.



TDEC-500
ELECTRONIC CONTROL SYSTEM

APPLICATIONS

- Oil field fracturing rigs
- Anchor hoists
- Large cranes
- Special purpose equipment

RATIOS

1st	2nd	3rd	4th	5th	6th	7th	8th	9th	Overall
4.47	3.57	2.85	2.41	1.92	1.54	1.25	1.00	0.80	5.60



Specifications subject to change without prior notice in the interest of continual product improvement.
Contact your local Twin Disc representative for engineering specifications. Patent pending.

Scan QR code to see Twin Disc's entire Power Transmission product line.



TA90-8703 AUTOMATIC TRANSMISSION SYSTEM

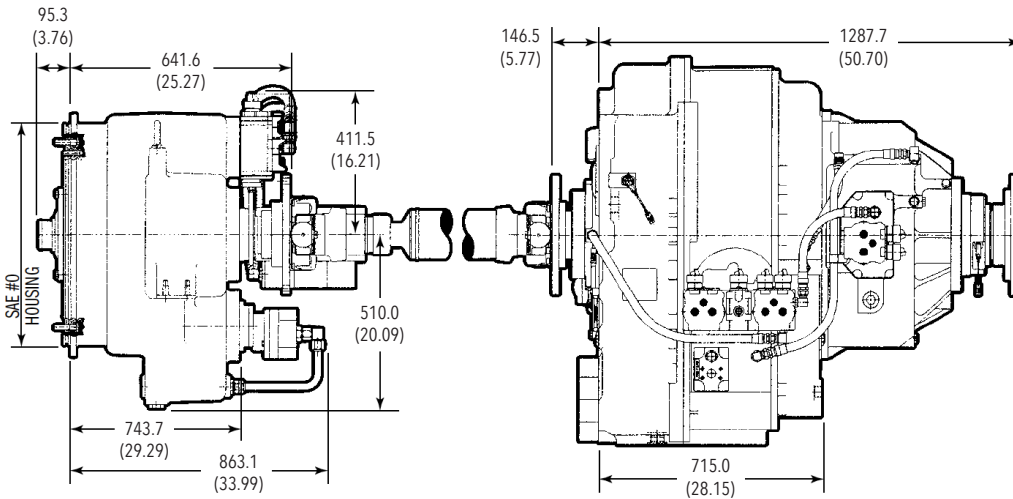

SPECIFICATIONS

TA90-8703	9 forward speeds, no reverse
Maximum gross input power	3300 hp (2460 kW) at 1900 RPM
Maximum gross input torque	6711 lb-ft (9098 Nm) in 1st 8401 lb-ft (11,390 Nm) in 2nd 9121 lb-ft (12,366 Nm) all other ranges
Maximum gross output torque	30,000 lb-ft (40,675 Nm)
Maximum input speed	1900 RPM*
Weight, dry	5380 lbs. (2440 kg)
Cooling pump capacity	100 GPM (379 l/min) @1900 RPM
Maximum oil temperature at converter outlet	250° F (121° C)
Sump capacity	35 USG (132 liters)
Remote mounted using "trunion" style mounts	
Cooling required 20 to 30% of GHP depending upon application	
*Consult Twin Disc if a maximum input speed over 1900 RPM is required.	

Important Notice: Torsional Vibration

Disregarding system torsional compatibility could cause damage to components in the drive train resulting in loss of mobility. At minimum, system incompatibility could result in gear clatter at low speeds.

The responsibility for ensuring that the torsional compatibility of the system is satisfactory rests with the assembler of the drive and driven equipment.

Torsional vibration analysis can be made by the engine builder, marine survey societies, independent consultants and others. Twin Disc is prepared to assist in finding solutions to potential torsional problems that relate to the transmission.

Twin Disc, Incorporated reminds users of these products that their safe operation depends on use in compliance with engineering information provided in our catalog. Users are also reminded that safe operation depends on proper installation, operation and routine maintenance and inspection under prevailing conditions. It is the responsibility of users (and not Twin Disc, Incorporated) to provide and install guards or safety devices which may be required by recognized safety standards or by the Occupational Safety and Health Act of 1970 and its subsequent provisions.

United States of America • Australia • Belgium • Canada • China • India • Italy • Singapore • Switzerland

For nearly a century, we've been putting horsepower to work by designing, engineering and manufacturing rugged-duty industrial products. Our products and our reputation are bolted to the most renowned engine manufacturers and equipment OEMs in the world. Our mission is to make your machines and vehicles more productive, more durable, more operator-friendly, more cost-effective. From design and installation consultation through after-sale support, Twin Disc and its distributors are committed to your business. No one knows more about managing horsepower in more ways than Twin Disc.

TRANSMISSIONS • CLUTCHES • PTOS
PUMP DRIVES • TORQUE CONVERTERS
GEARBOXES • HYDRAULIC PTO PRODUCTS



Twin Disc, Incorporated
Racine, Wisconsin 53403 USA
Phone +1-262-638-4000
Fax +1-262-638-4482
www.twindisc.com

TD-Bulletin-TA90-8703
© 2016, Twin Disc, Incorporated
Printed in the USA - 3/2016